

Alert Message Communications

- **Deviation from RSDO Catalog Impacts Cost and Schedule**
- **Original 5 Second to Internet Requirement is High Risk**
 - **Change to 7 Seconds Should be Reasonable**
- **1 ms C&DH Processing Requirement Breaks Vendors Design - \$,\$\$\$,\$\$\$.\$\$**
- **On-Board Bus Architecture can Improve Response Time**

Response Time Constraints

Alert Message Communications

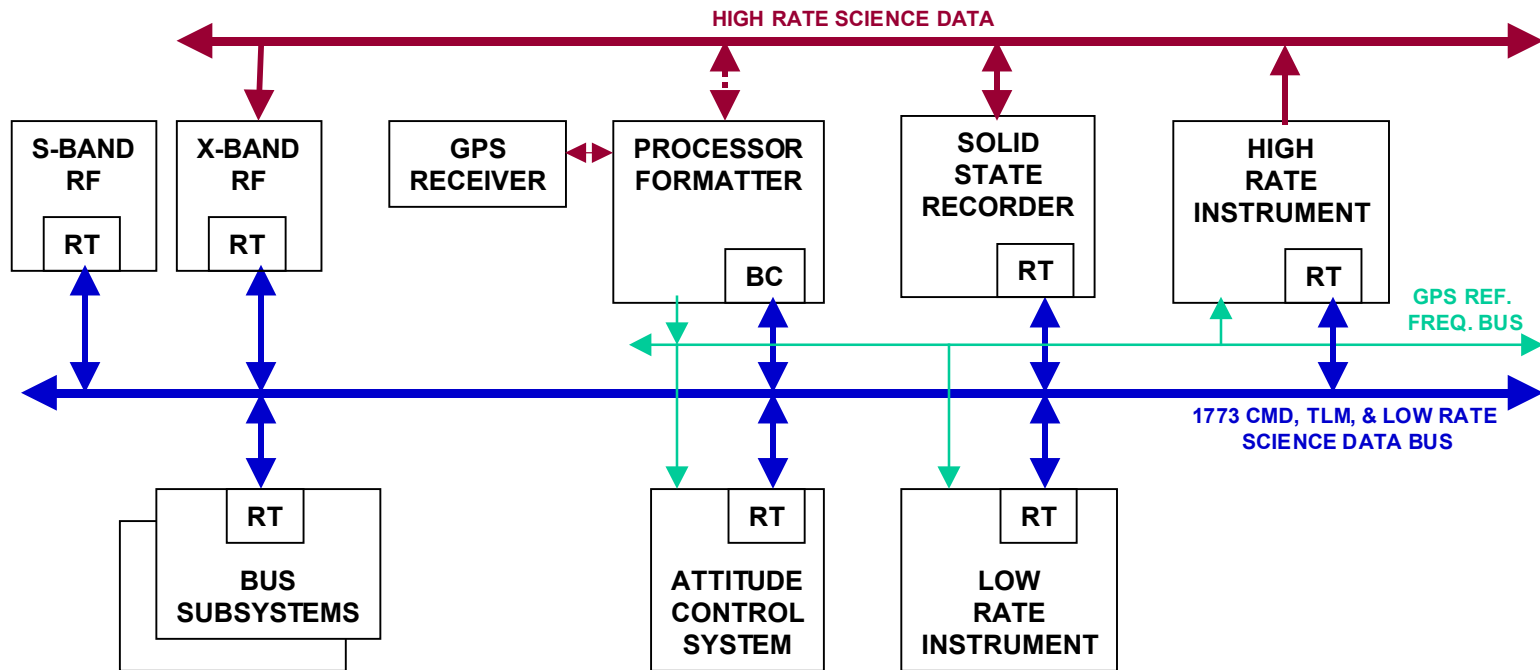

BASELINE GLAST C&DH

Alert Message Communications

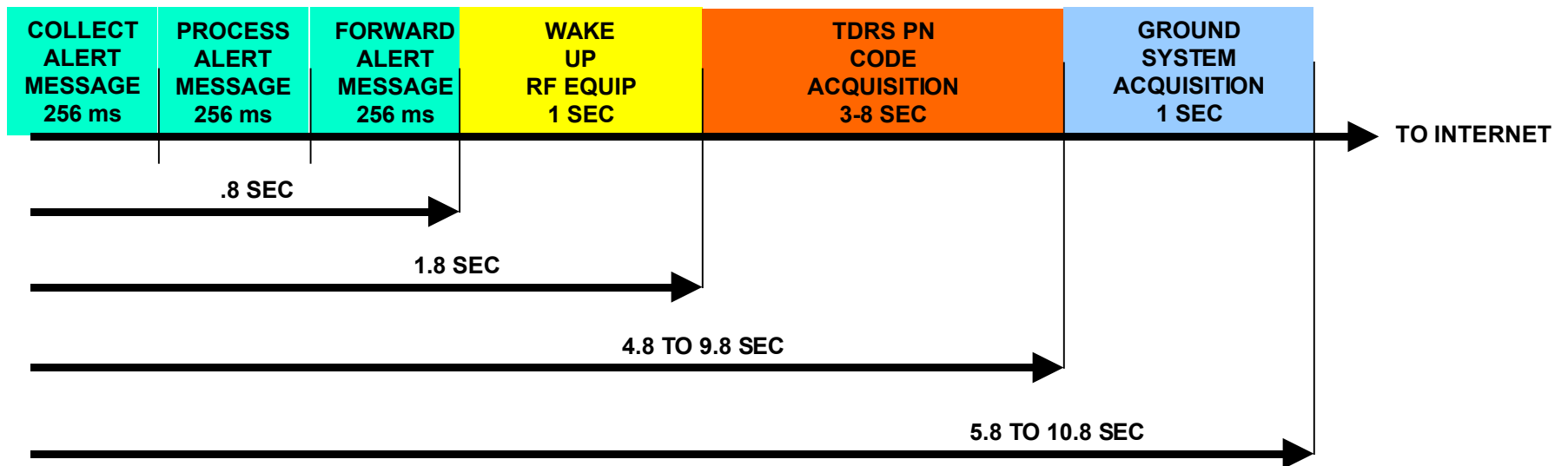

TIMELINE

Alert Message Communications

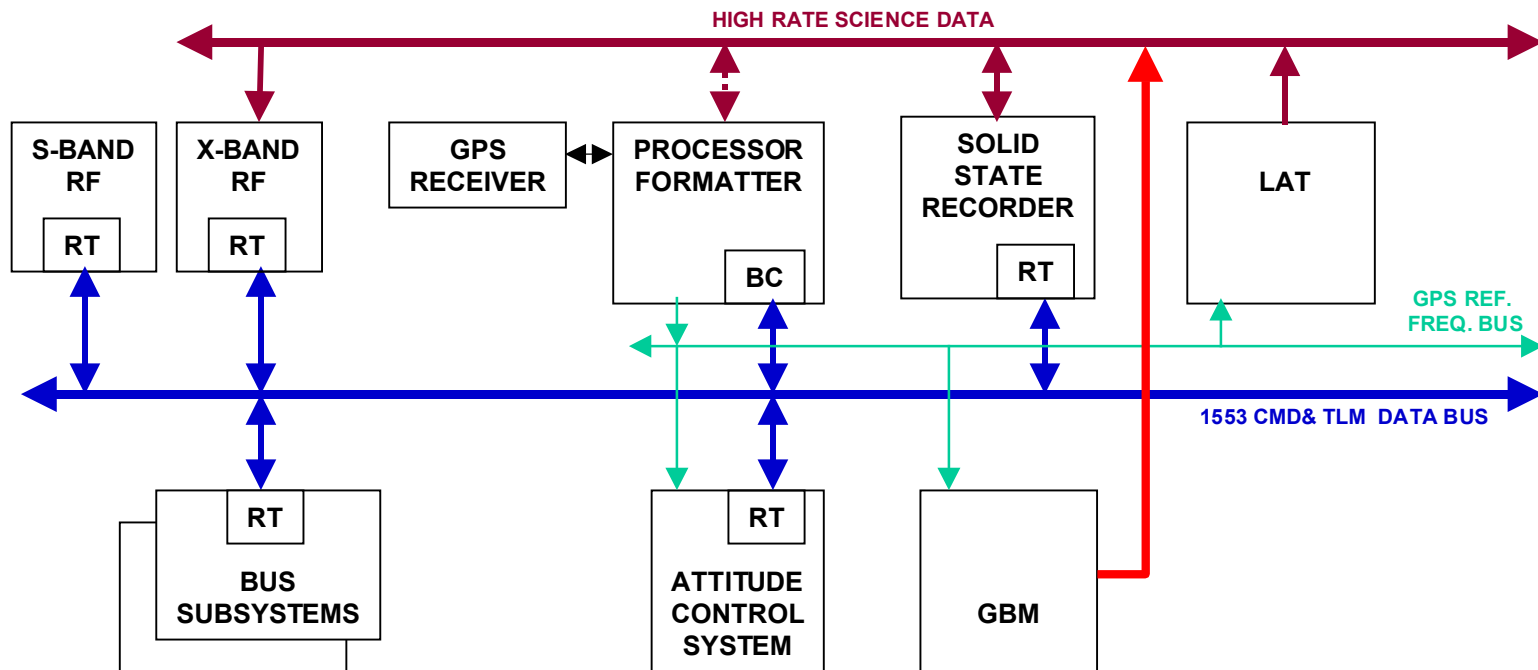

LAT and GBM on HIGH RATE BUS

Alert Message Communications

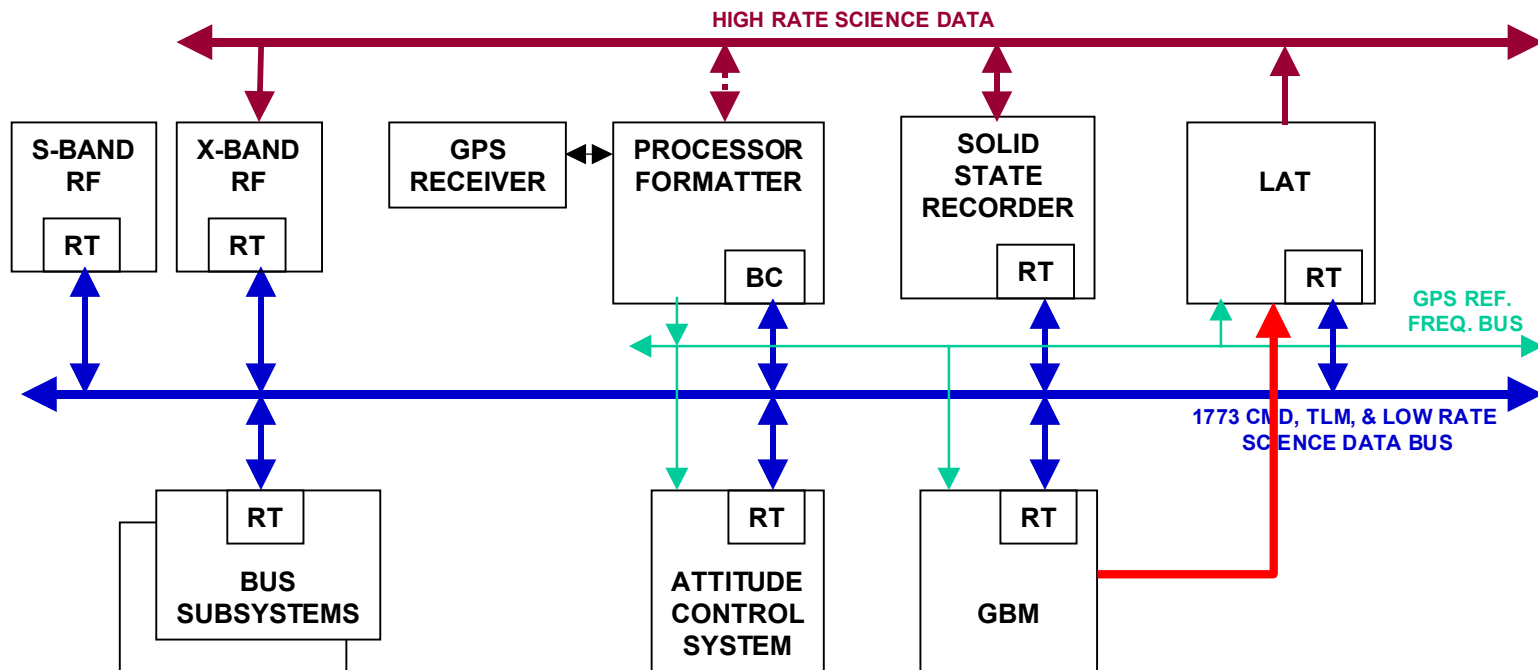

DIRECT CONNECT GBM to LAT